

HEISLER

EMPTY PAIL UPSTACKERS



HEISLER offers several types of pail upstackers depending on speed, container size, and handle-to-label orientation needs. Designed to be compact and economical, these units are capable of speeds ranging from 20 to 30 pails/minute depending on the model.

Manufactured by Heisler, this machine can be configured with only the features you need. Many standard options are available along with any custom design requests.



Machine Operation

Pails, with or without bails, not having orientation are indexed into an orienting station to spin and properly locate the bail or ear. They are then released to the Upstacker.

Pails, with or without bails, having orientation are kept oriented on the infeed conveyor using an ear rail. They are then indexed directly into the Upstacker.

In the Upstacker, the pail is lifted and captured by opposing jaws which hold it by the satellite rings. A stack control mechanism remains in contact with the stack as it is being formed to maintain control and stability. When the proper number of stacked pails is reached, the stack is released.

Machine Options

- Label Orientation.
- Stainless Steel Construction.
- Adjustable features.
- Steel-it Paint

Machine Features

- Completely wired and ready to go.
- Trouble alarms.
- Turk Proximity Sensors.
- Banner Photoelectric Sensors.
- Mac Solenoid Valves.
- Allen Bradley Control Components.
- Control Voltage 24VDC.

www.heislerind.com

HEISLER
QUALITY, DURABILITY, SERVICE

"We are dedicated to the success of your project"



Denesters • Case/Tray Packers • Lid Placers • Palletizers
Labelers • Bail-O-Matics • Turn Tables • System Integration

...choice labeling solutions™

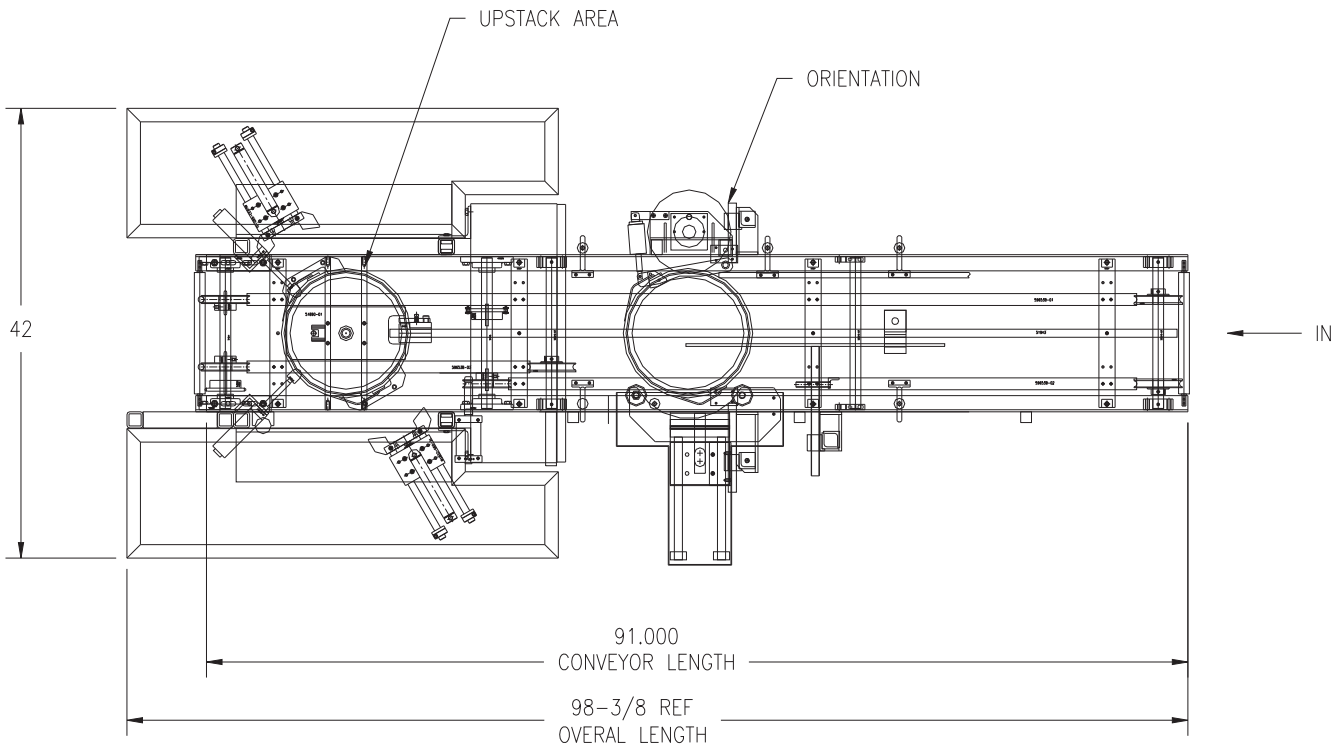

Model with Orientation station shown

Technical Specification	Empty Pail Upstacker
Speed	Up to 30 pails/Min. dependant on model and pail configuration
Alignment Accuracy	+/- 5 degrees
Controls	Allen Bradley Micrologix PLC
Electrical	220/440 VAC, 3 Phase, 60 Hertz
Air	6 CFM @ 80 PSI
Weight, net approximately.	2,700 lbs.

HEISLER
QUALITY, DURABILITY, SERVICE

224 Passaic Ave, Fairfield, NJ
TEL 973-227-6300 • FAX 973-227-7627
www.heislerind.com